

# **Quick Guide**

## **Extra Communication Card**

## **Uninterruptible Power Supply System**

**Version: 1.0**

# Table of Contents

<b>1.</b>	<b>Product Outlook</b> .....	3
<b>2.</b>	<b>Product Introduction</b> .....	3
<b>2.2.</b>	<b>RS232 port</b> .....	4
<b>2.3.</b>	<b>COMM. Slot</b> .....	4
<b>2.4.</b>	<b>Dry Contact Output</b> .....	4
<b>2.6.</b>	<b>Dry Contact Input</b> .....	5
<b>2.7.</b>	<b>External Battery Cabinet Temperature (Option)</b> .....	5
<b>2.8.</b>	<b>LED</b> .....	6
<b>3.</b>	<b>Installation</b> .....	6
<b>4.</b>	<b>Configuration</b> .....	8
<b>5.</b>	<b>Jumper Set-up</b> .....	10

# 1. Product Outlook

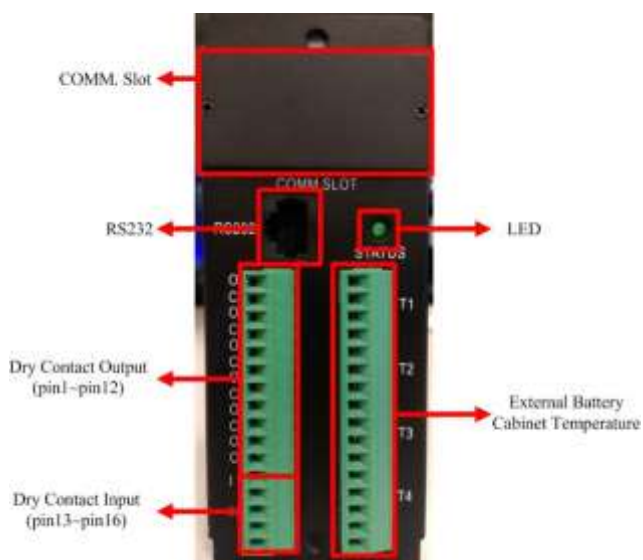
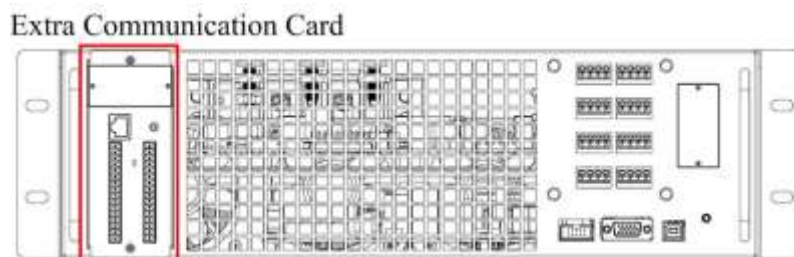

## 2. Product Introduction

Extra communication card is a device with additional interface functionality. This device can provide a variety different applications for UPS. The communication interfaces of extra communication card are listed below:

- RS232 port
- COMM. Slot
- Dry Contac Output
- Dry Contact Input
- External Battery Cabinet Temperature
- LED

## 2.2. RS232 port

The RS232 port can use for not only monitoring UPS status via monitoring software but also setting dry contact function with supplied utility tool.

## 2.3. COMM. Slot

This extra communication card has facility of internally fitted optional SNMP card.

## 2.4. Dry Contact Output

These 6 dry contact outputs can be set to normally open or normally close by setting jumper. Please refer to the Chapter 5 Jumper Set-up for the details. It's also able to set the feature of each dry contact output port though the Extra Com Config tool software. Please refer to Chapter 4 Configuration for the details.

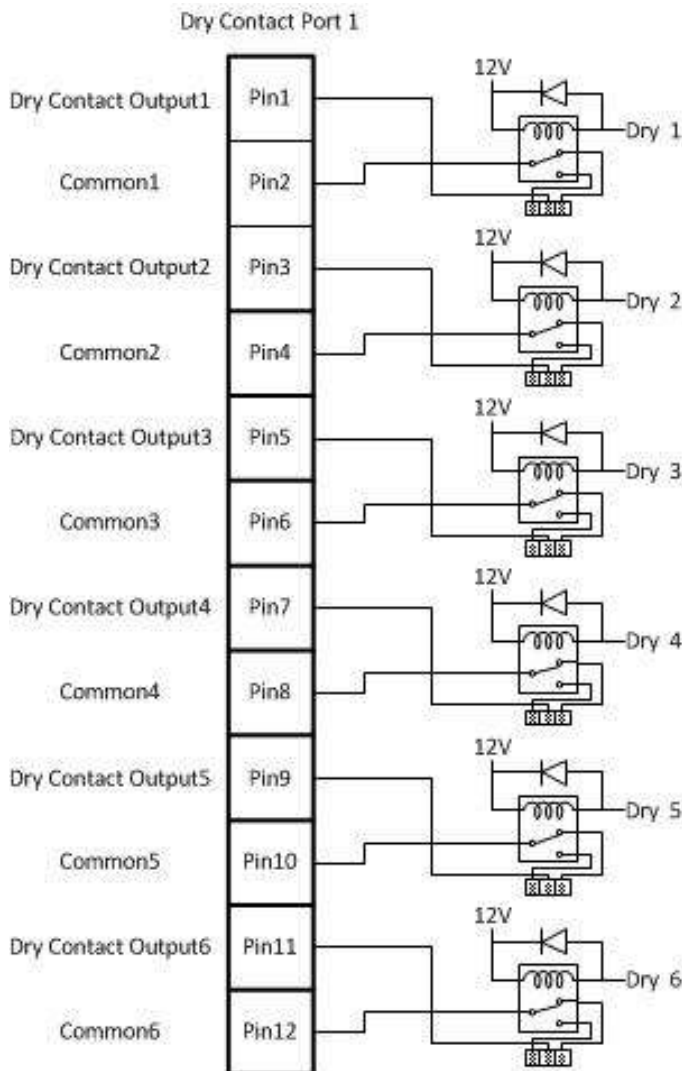

## 2.6. Dry Contact Input

There are two sets of dry contact input to receive external signals for UPS to take response.

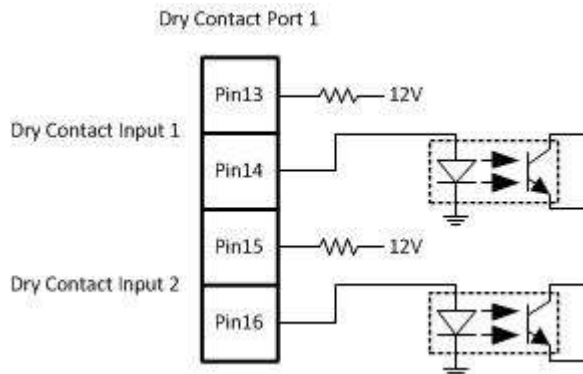

## 2.7. External Battery Cabinet Temperature (Option)

You may order "sensor kit" (optional accessory) to detect the temperature of external battery cabinet.

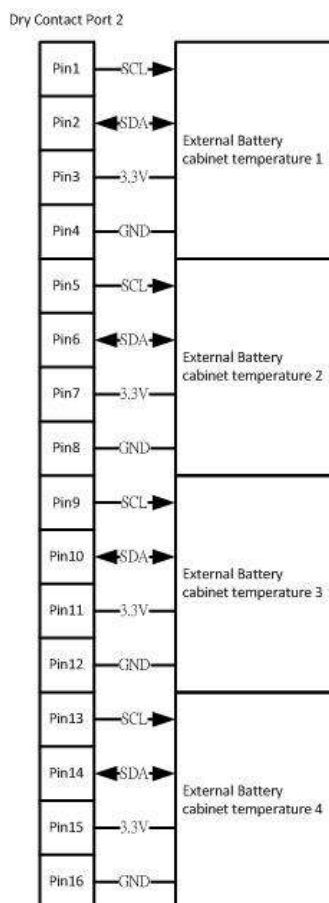

## 2.8. LED

The green LED represents operation status of the extra communication card.

Please refer to below table.

Color	Status	Definition
Green	Flashing	Communications: On/0.1s, Off/0.4s. Un-Connection: On/0.1s, Off/0.41.
	Off	ID conflict or Power off

## 3. Installation

Step 1. Remove cover of slot on the STS module.



Step 2. Insert extra communication card into slot.



Step 3. The cover of extra communication card should attach close to STS module. Secure the extra communication card to the STS module chassis with 2 screws.



Step 4. Use RJ45 cable to connect UPS and equipment to implement remote monitoring and control.



## 4. Configuration

Step 1: Please access [www.power-software-download.com](http://www.power-software-download.com) to install utility tool for Extra Communication in your computer. After software is installed successfully, it will pop up a plug icon in the tray.

Step 2: Start Extra Com Config software tool in your computer. Then, it will pop up a screen as Fig. 6.



Fig. 6

Step 3: Click "Read Setting" button to check the current setting of the dry contact output port. Refer to screen in Fig. 7.

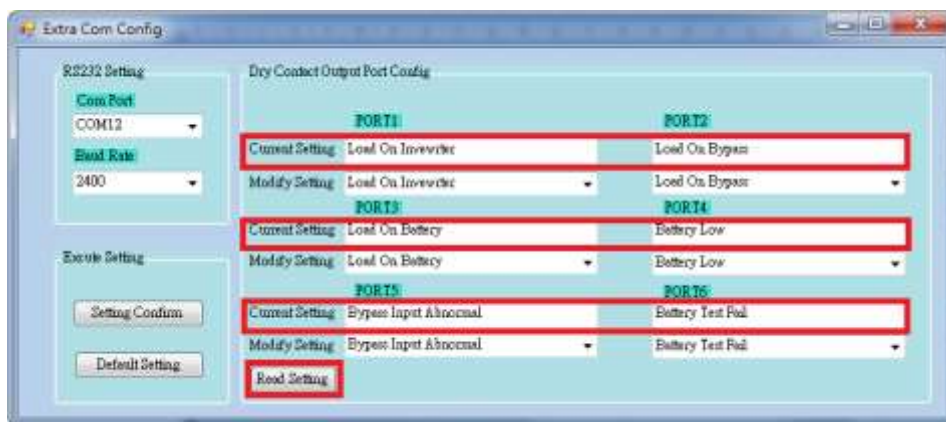

Fig. 7

Step 4: Check all settings.

There are 20 messages to select for contact and listed in table 1. Once dry contact output settings are selected, click "Setting Confirm" button.



Table 1:

Contact	Message	Description
1	Load on inverter	The UPS is working normally.
2	Load on bypass	The UPS is in Bypass mode.
3	Load on Battery	The UPS is in Battery mode.
4	Low battery	The battery voltage is low.
5	Bypass input abnormal	The bypass voltage or frequency is abnormal.
6	Battery test failure	Performs the battery test. The battery test fails.
7	Internal communication failure	DSP and MCU stop communication in power module.
8	External parallel communication failure	Communication error between power modules.
9	Output overload warning/shutdown	Connected load is over rated output of the UPS.
10	Power module fault shutdown	The module fails and the UPS shuts down.
11	Power module warning	The module has errors, but the UPS can still function normally.
12	EPO Active	Urgently power off the UPS.
13	Maintain Bypass	The UPS transfers to Maintain bypass mode.
14	Module over temperature warning/shutdown	The temperature is too high.
15	Battery replacement	Overdue for battery replacement (Compared with system setup.)
16	Bypass over temperature warning/shutdown	Bypass "static transfer switch" is over temperature.
17	Bypass static switch fault	The bypass "static transfer switch" is abnormal.
18	Line AC fail	Power failure
19	Bypass failure	Bypass source fails
20	Redundancy failure	Redundancy setting error.



Fig. 8

"Default Setting" button: It's to set all configurations back to default value. Refer to Fig. 9.



Fig. 9

## 5. Jumper Set-up

Dry contact output port can be set normally open or normally close from JP1 to JP6. The 3-pin connectors can be easily found just nearby relay. The ID number of the Extra communication card can be set 60 or 61 in JS1. Please refer to Fig. 10.

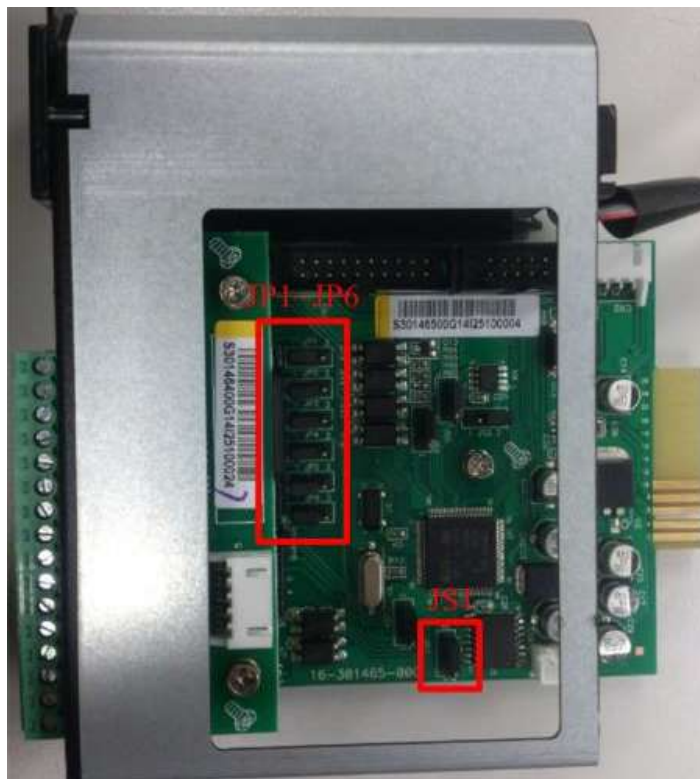

Fig10

Connect pin 1 and pin 2 of JP1 to set normally open type for dry contact output port. Same connection is applied from JP1 to JP6. Refer to Fig. 11.

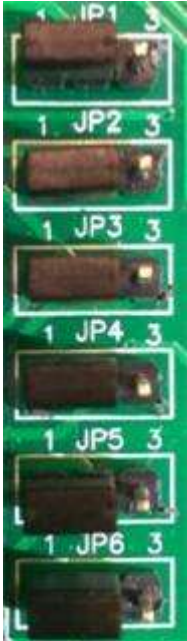

Fig. 11

Connect pin 2 and pin 3 of JP1 to set normally close type for dry contact output port. Same connection is applied from JP1 to JP6. Refer to Fig. 12.

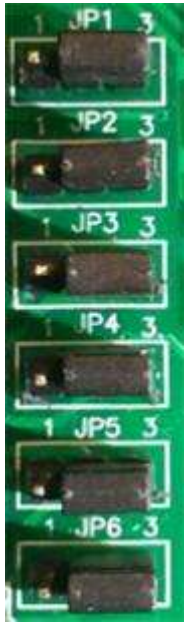

Fig. 12

Please connect pin 1 and pin 2 of JS1 to set ID number of Extra communication card as 60 in JS1. Refer to Fig. 13.



Fig. 13

Please connect pin 2 and pin 3 of JS1 to set ID number of Extra communication card as 61 in JS1. Refer to Fig. 14.



Fig. 14